



M9000-310 and M9000-320 Series Weather Shield Enclosures

Installation Instructions

Part No. 14-1330-18, Rev. B
Issued June 2016

Refer to the [QuickLIT website](#) for the most up-to-date version of this document.

Applications

The M9000-310 and M9000-320 Weather Shield Enclosures are cost-effective and durable weather shields designed to provide a degree of protection for a single Johnson Controls® M9000 Series Electric Actuator used in either control damper or iron flanged valve applications. These weather shield enclosures are manufactured to National Electrical Manufacturers' Association (NEMA) 3R specifications and protect the electric actuator from corrosion, rain, freezing rain, sleet, and snow. The enclosure can be mounted indoors or outdoors; however, it may not prevent externally formed ice from restricting the motion of the rotary shaft.

Each enclosure is constructed of impact-grade ABS plastic that provides excellent impact resistance. The cover features ultraviolet inhibitors that extend service life by preventing the cover from becoming brittle or damaged by the sun or other environmental elements. The transparent cover provides an unobstructed view of the electric actuator without having to disassemble the enclosure. An appliance cord enables installation of control wiring, and a form-fitting seal prevents water or moisture from entering the unit and damaging the actuator.

IMPORTANT: The M9000-310 and M9000-320 Weather Shield Enclosures only provide protection for the Johnson Controls M9000 Series Electric Actuator used in control damper and iron flanged valve applications. To ensure proper operation, check that all associated equipment used in the application is suitable for the surrounding environment.

Installation

Refer to the following documentation for more information on the M9000 Series Electric Actuators and Valve Linkages used with the M9000-310 and M9000-320 Weather Shield Enclosures:

- *M9106-xGx-2 Series Electric Non-Spring Return Actuators Installation Instructions (Part No. 34-636-1085)*
- *M9108, M9116, M9124, and M9132 Series Electric Non-Spring Return Actuators Installation Instructions (Part No. 34-636-399)*
- *M9109 Series Electric Non-spring Return Actuators Installation Instructions (Part No. 34-636-1190)*
- *M9220-AGx-3 Floating Electric Spring Return Actuators Installation Instructions (Part No. 34-636-1689)*
- *M9220-Bxx-3 On/Off Electric Spring Return Actuators Installation Instructions (Part No. 34-636-1239)*
- *M9220-GGx-3 Proportional Electric Spring Return Actuators Installation Instructions (Part No. 34-636-1697)*
- *M9000-53x Cast Iron Flanged Valve Linkage Kit for Mounting a Single M9000 Series Electric Actuator Installation Instructions (Part No. 14-1298-18)*
- *M9000-53x Series Cast Iron Flanged Valve Linkage Kit for Tandem Mounting of M9000 Series Electric Actuators Installation Instructions (Part No. 14-1298-26)*

Parts Included

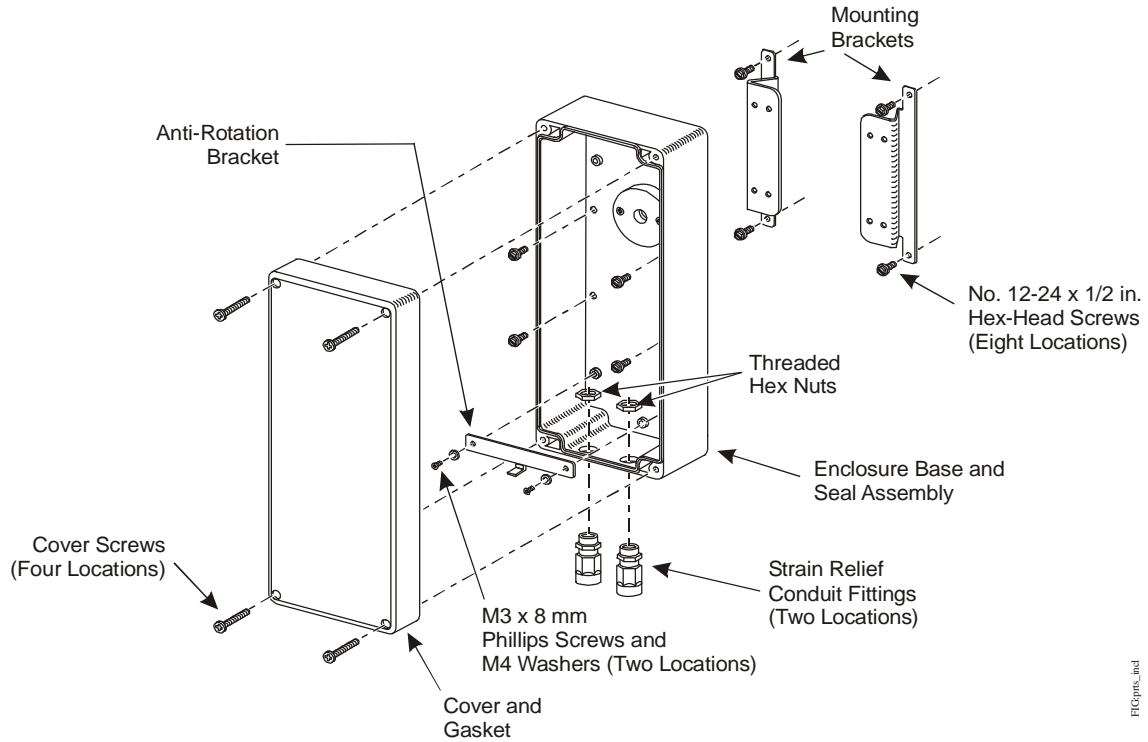

Figure 1: Parts Included in M9000-310 and M9000-320 Weather Shield Enclosure Kits (See Table 1)

Table 1: Parts Included in M9000-310 and M9000-320 Weather Shield Enclosure Kits

Quantity	Description
1	Enclosure Base and Seal Assembly
1	Cover and Gasket
4	Cover Screws
2	Mounting Brackets
8	No. 12-24 x 1/2 in. Hex-Head Screws with Nitrile Patch
1	Anti-Rotation Bracket
2	M3 x 8 mm Phillips Screws
2	M4 Washers
2	Strain Relief Conduit Fittings with 1/2 in. National Pipe Straight Mechanical (NPSM) Exit ¹
1	Cap Plug
2	Threaded Hex Nuts
1	Appliance Cord - 6 Conductor, 18 AWG Wire Gauge, 43 in. (109 cm)
1	Shaft Extender with Set Screw (M9000-320 Kit Only)

1. It is recommended that 1/2 in. liquid-tight conduit and 1/2 in. National Pipe Thread (NPT) liquid-tight fittings (purchased locally) be used to terminate the control wiring to the weather shield enclosure strain relief conduit fittings.

Dimensions

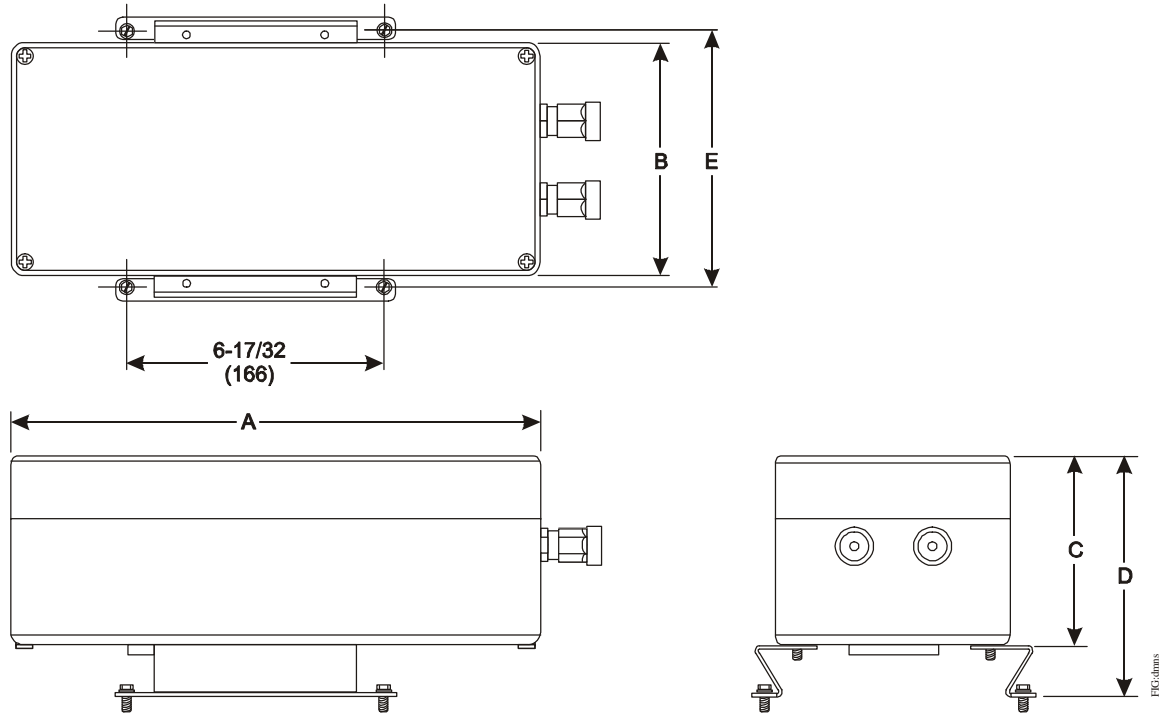

**Figure 2: Weather Shield Enclosure Dimensions, in. (mm)
(See Table 2.)**

Table 2: Weather Shield Enclosure Dimensions, in. (mm)

Dimension	Weather Shield Enclosure	
	M9000-310	M9000-320
A	7-7/8 (200)	13-3/8 (340)
B	4-23/32 (120)	5-29/32 (150)
C	3-17/32 (90)	4-23/32 (120)
D	4-27/32 (123)	6-1/32 (153)
E	5-13/32 (137)	6-9/16 (167)

Mounting

The M9000-310 and M9000-320 Weather Shield Enclosure Kits are shipped from the factory partially assembled, with the cover held in place using the four cover screws included with the kit. The remainder of the parts required for mounting can be found inside the enclosure.

Control Damper Applications

Mount the weather shield enclosure onto a control damper as follows:

1. Loosen the four cover screws using a No.1 Phillips screwdriver and remove the cover and gasket assembly from the enclosure base.
2. Orient the anti-rotation bracket onto the enclosure as illustrated in Figure 3.

Note: The anti-rotation bracket must be oriented properly for the anti-rotation tab to align with the slot on the electric actuator.

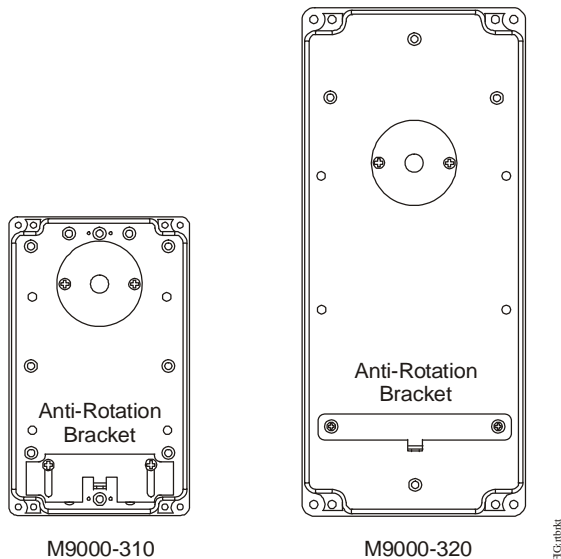

Figure 3: Proper Orientation of the Anti-Rotation Bracket

3. Secure the anti-rotation bracket to the threaded brass inserts of the enclosure base using two M3 x 8 mm Phillips screws and M4 washers included with the kit. Tighten the Phillips screws to a torque of 15 to 20 lb-in (1.7 to 2.3 N·m).

IMPORTANT: Do not overtighten the Phillips screws. Overtightening may cause the threaded inserts located in the enclosure base to become dislodged, resulting in damage to the enclosure.

4. Orient the two mounting brackets onto the enclosure base as illustrated in Figure 4.

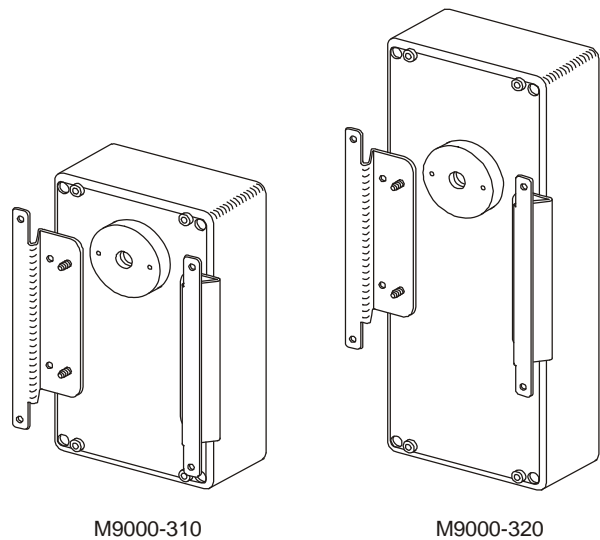

Figure 4: Proper Orientation of the Mounting Brackets onto the Enclosure Base

5. Secure the mounting brackets to the enclosure base using four No. 12-24 x 1/2 in. hex-head screws (included with the kit).

Note: Each hex-head screw should be inserted from the inside of the enclosure so that the nitrile patch seals the mounting hole in the base.

6. Install the enclosure and mounting bracket assembly onto the damper shaft extension. Orient the assembly so that the flanges of the mounting brackets are flush with the mounting surface.
7. Using the mounting brackets as a template, mark the mounting hole locations with a ball-peen hammer and punch.
8. Remove the enclosure and mounting bracket assembly from the damper shaft extension.
9. Drill pilot holes at each of the marked spots using a drill and a No. 10 drill bit.
10. Reinstall the enclosure and mounting bracket assembly onto the damper shaft extension. Orient the assembly so that the flanges of the mounting brackets are flush with the mounting surface and the holes in the mounting brackets align with the pilot holes drilled in Step 9.
11. Secure the enclosure and mounting bracket assembly to the mounting surface using four No. 12-24 x 1/2 in. hex-head screws included with the kit. Tighten the hex-head screws to a torque of 20 to 25 lb-in (2.3 to 2.8 N·m).

12. Install the two conduit fittings included with the kit into the enclosure base and secure them in place using the threaded hex nuts.

IMPORTANT: The conduit fittings must be installed properly to ensure a tight seal. Water or moisture may damage or affect the operation of the electric actuator within the enclosure.

13. Insert the appliance cord into one of the conduit fittings so that the cable wrapping is visible inside the enclosure. Tighten the conduit fitting to a torque of 10 to 15 lb-in (1.1 to 1.7 N·m) to secure the appliance cord in place.
14. Install the electric actuator onto the damper shaft extension and the enclosure anti-rotation bracket.

Note: Refer to the documentation included with the electric actuator for complete installation instructions.

15. Reinstall the cover and gasket assembly and secure it in place using the four cover screws included with the kit. Tighten the cover screws to a torque of 5 to 8 lb-in (0.6 to 0.9 N·m) maximum.

IMPORTANT: The cover and gasket assembly must be installed properly to ensure a tight seal. Water or moisture may damage or affect the operation of the electric actuator within the enclosure.

16. If one of the conduit fittings remains unused, seal the fitting using the cap plug included with the enclosure kit.

Iron Flanged Valve Applications

Mount the weather shield enclosure onto the M9000-53x Series Valve Linkage as follows:

1. Loosen the four cover screws using a No. 1 Phillips screwdriver and remove the cover and gasket assembly from the enclosure base.
2. Orient the anti-rotation bracket onto the enclosure as illustrated in Figure 3.

Note: The anti-rotation bracket must be oriented properly in order for the anti-rotation tab to align with the slot on the electric actuator.

3. Secure the anti-rotation bracket to the threaded brass inserts of the enclosure base using two M3 x 8 mm Phillips screws and M4 washers included with the kit. Tighten the Phillips screws to a torque of 15 to 20 lb-in (1.7 to 2.3 N·m).

IMPORTANT: Do not overtighten the Phillips screws. Overtightening may cause the threaded inserts located in the enclosure base to become dislodged, resulting in damage to the enclosure.

4. Orient the two mounting brackets onto the primary side of the M9000-53x Series Valve Linkage (for single-mount applications) as illustrated in Figure 5.

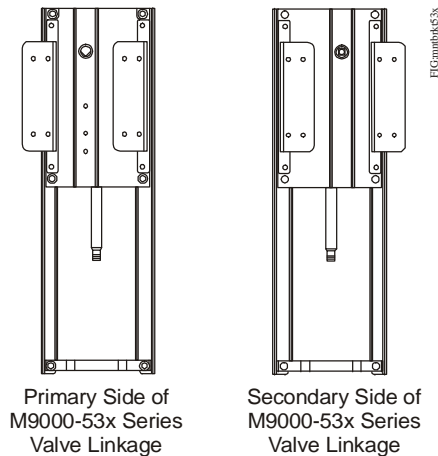

Figure 5: Proper Orientation of the Mounting Brackets onto the M9000-53x Series Valve Linkage

5. Secure the mounting brackets to the M9000-53x Series Valve Linkage using four No. 12-24 x 1/2 in. hex-head screws (included with the kit).
6. Install the enclosure onto the input shaft of the M9000-53x Series Valve Linkage. Orient the enclosure so that the flanges of the mounting brackets are flush with the surface of the enclosure base.
7. Secure the enclosure to the mounting brackets using four No. 12-24 x 1/2 in. hex-head screws included with the kit. Tighten the hex-head screws to a torque of 20 to 25 lb-in (2.3 to 2.8 N·m).

Note: Each hex-head screw should be inserted from the inside of the enclosure so that the nitrile patch seals the mounting hole in the base.

- Install the two conduit fittings included with the kit into the enclosure base and secure them in place using the threaded hex nuts.

IMPORTANT: The conduit fittings must be installed properly to ensure a tight seal. Water or moisture may damage or affect the operation of the electric actuator within the enclosure.

Steps 9 and 11 apply only to the M9000-320 kit when used with the M9220 Series actuators. For the M9000-310 kit, proceed to Step 12.

- For the M9000-320 kit used with the M9220 Series actuators, install the shaft extension onto the input shaft of the valve linkage. Ensure that the set screws located on the shaft extension are oriented perpendicular to the flat surfaces on the input shaft. (See Figure 6.) To reduce friction, ensure that the shaft extension and the seal assembly are not in contact. A gap of no more than 1/8 in. is recommended between these two components.

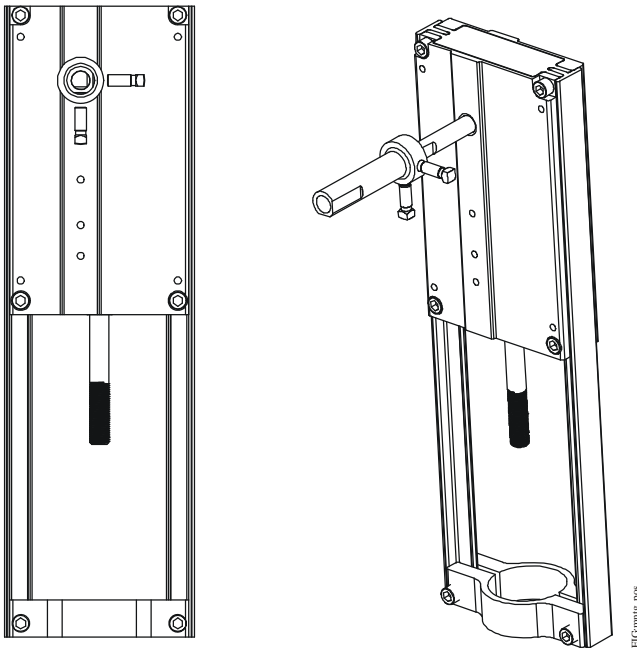

Figure 6: Proper Mounting Position for Shaft Extension

- Secure the shaft extension to the input shaft of the valve linkage using the supplied set screws and 5/16 in. (8 mm) wrench. The recommended torque applied to the set screws is 100 in·lb (11 N·m). Tighten the screws evenly.

- Using a flat blade screwdriver, remove and save the spring clip from the M9220 actuator hub and gripper assembly. Remove the actuator gripper assembly from the actuator and retain.
- Insert the appliance cord(s) for the actuator through the conduit fittings.
- Install the actuator into the enclosure/linkage assembly. Insert the actuator anti-rotation slots over the anti-rotation tab of the bracket from Step 3.
- Center the shaft or shaft extension in the actuator hub. For the M9220, reinstall the actuator gripper assembly and secure in place using the spring clip. Secure the actuator coupler assembly to the shaft following the actuator mounting instructions.

Note: Refer to the documentation included with the electric actuator and valve linkage for complete installation instructions.

- Tighten the conduit fitting to a torque of 10 to 15 lb-in (1.1 to 1.7 N·m) to secure the appliance cord in place.
- Reinstall the cover and gasket assembly and secure it in place using the four cover screws included with the kit. Tighten the cover screws to a torque of 5 lb-in (0.6 N·m) maximum.
- If the valve application is a tandem configuration, repeat Steps 11 through 16 on the secondary side of the M9000-53x Series Valve Linkage.

IMPORTANT: The cover and gasket assembly must be installed properly to ensure a tight seal. Water or moisture may damage or affect the operation of the electric actuator within the enclosure.

- If one of the conduit fittings remains unused, seal the fitting using the cap plug included with the enclosure kit.

Repair Information

If the M9000-310 or M9000-320 Series Weather Shield Enclosure fails to operate within its specifications, replace the unit. For a replacement weather shield, contact the nearest Johnson Controls representative.

Technical Specifications

M9000-310 and M9000-320 Weather Shield Enclosures

Materials	Enclosure	Impact-Grade ABS Plastic
	Enclosure Seal	Nitrile
	Cover	Transparent Impact-Grade ABS Plastic with Ultraviolet Inhibitors
	Cover Gasket	Neoprene
Weather Shield Rating		NEMA 3R, IP32
Actuator Ambient Operating Temperature Limits	M9106 and M9109 (M9000-310 Only)	-4 to 122°F (-20 to 50°C)
	M9108, M9116, M9124, and M9132	-4 to 122°F (-20 to 50°C)
	M9220	-40 to 131°F (-40 to 55°C)
Weather Shield Enclosure Ambient Storage Temperature Limits		-40 to 176°F (-40 to 80°C)
Electrical Connections		Strain Relief Conduit Fittings with 1/2 in. National Pipe Straight Mechanical (NPSM) Exit
Shipping Weight	M9000-310	2.0 lb (0.9 kg)
	M9000-320	3.3 lb (1.5 kg)

The performance specifications are nominal and conform to acceptable industry standards. For application at conditions beyond these specifications, consult the local Johnson Controls office. Johnson Controls, Inc. shall not be liable for damages resulting from misapplication or misuse of its products.

European Single Point of Contact:

JOHNSON CONTROLS
WESTENDHOF 3
45143 ESSEN
GERMANY

NA/SA Single Point of Contact:

JOHNSON CONTROLS
507 E MICHIGAN ST
MILWAUKEE WI 53202
USA

APAC Single Point of Contact:

JOHNSON CONTROLS
C/O CONTROLS PRODUCT MANAGEMENT
NO. 22 BLOCK D NEW DISTRICT
WUXI JIANGSU PROVINCE 214142
CHINA



Building Efficiency

507 E. Michigan Street, Milwaukee, WI 53202

Metasys® and Johnson Controls® are registered trademarks of Johnson Controls, Inc. All other marks herein are the marks of their respective owners. © 2016 Johnson Controls, Inc.